

DRAWING MADE IN THIRD ANGLE PROJECTION

© COPYRIGHT 1979 BY AMP INCORPORATED, HARRISBURG, PA. ALL INTERNATIONAL RIGHTS RESERVED. AMP INCORPORATED PRODUCTS COVERED BY U. S. AND FOREIGN PATENTS AND/OR PATENTS PENDING.

LOC DF HO

REVISIONS					
P	F	ZONE	LTR	DESCRIPTION	DATE APPROVED
	✓		O1	REVISED 6180 MS	8-79
	✓		O2	REVISED 7336 DE	4-81
	✓		P	085-7-8,9,10,11; RECALDF 09 09	2P 11/88 JW

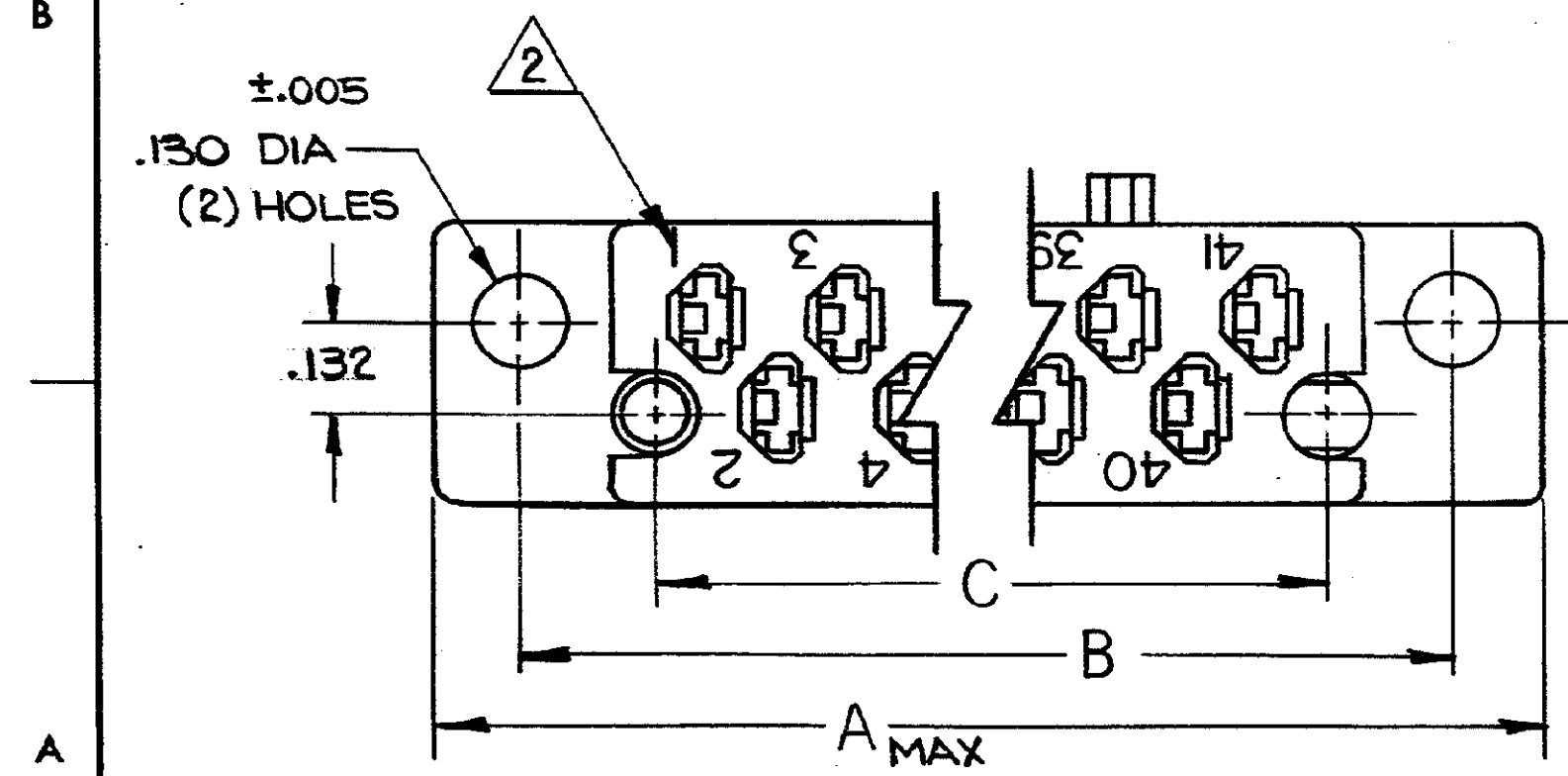
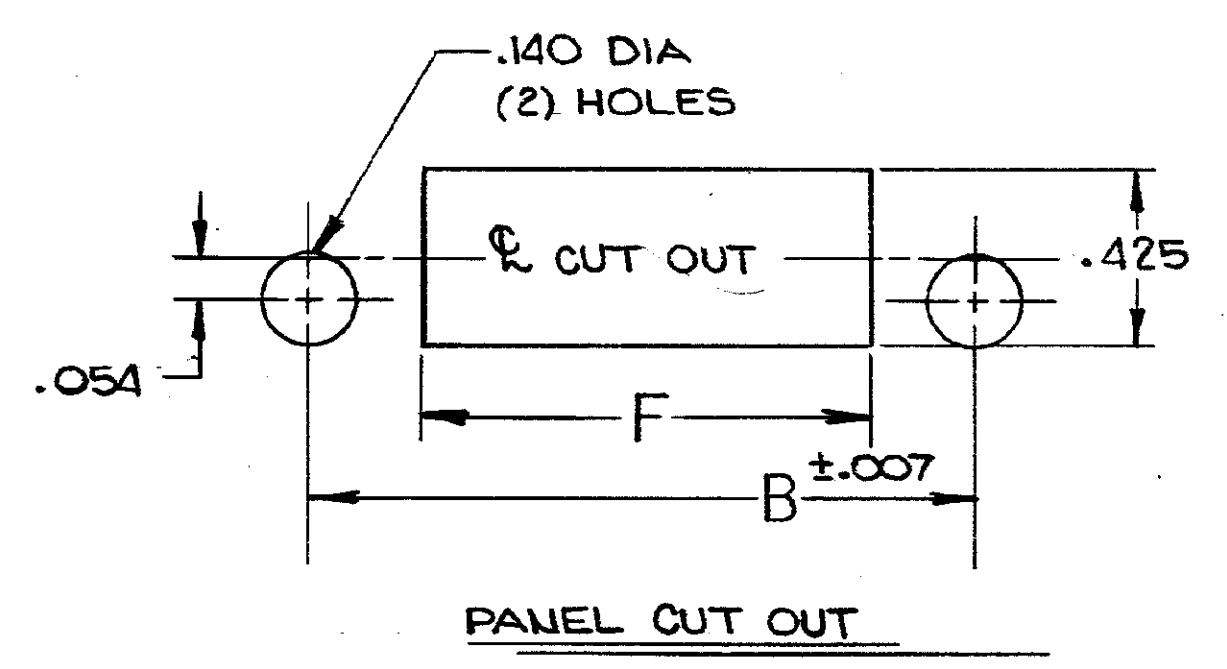
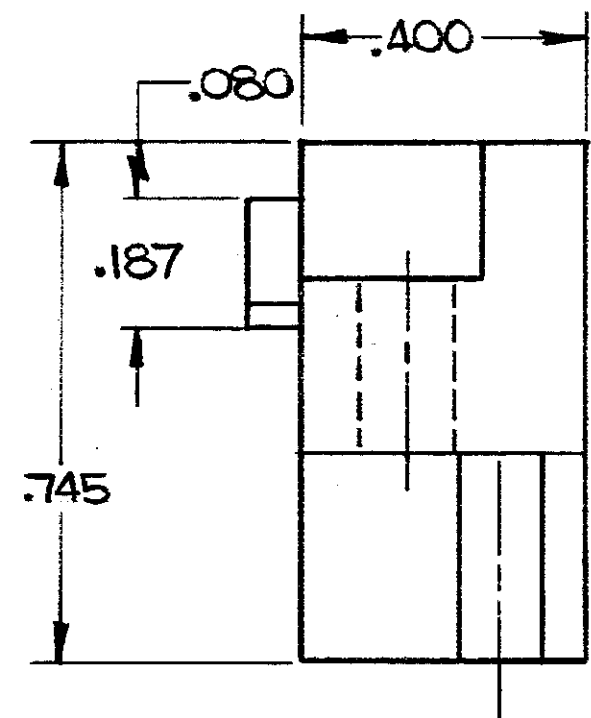
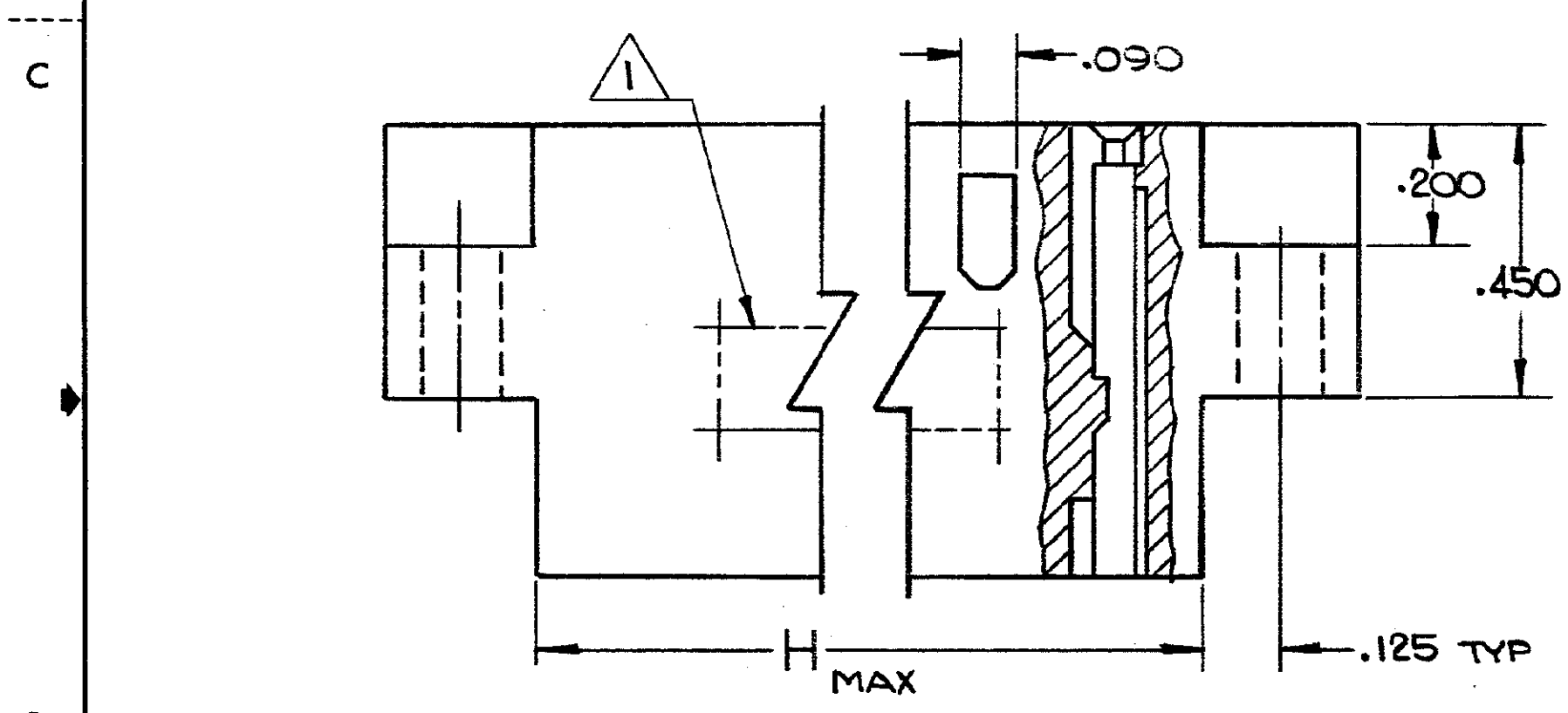
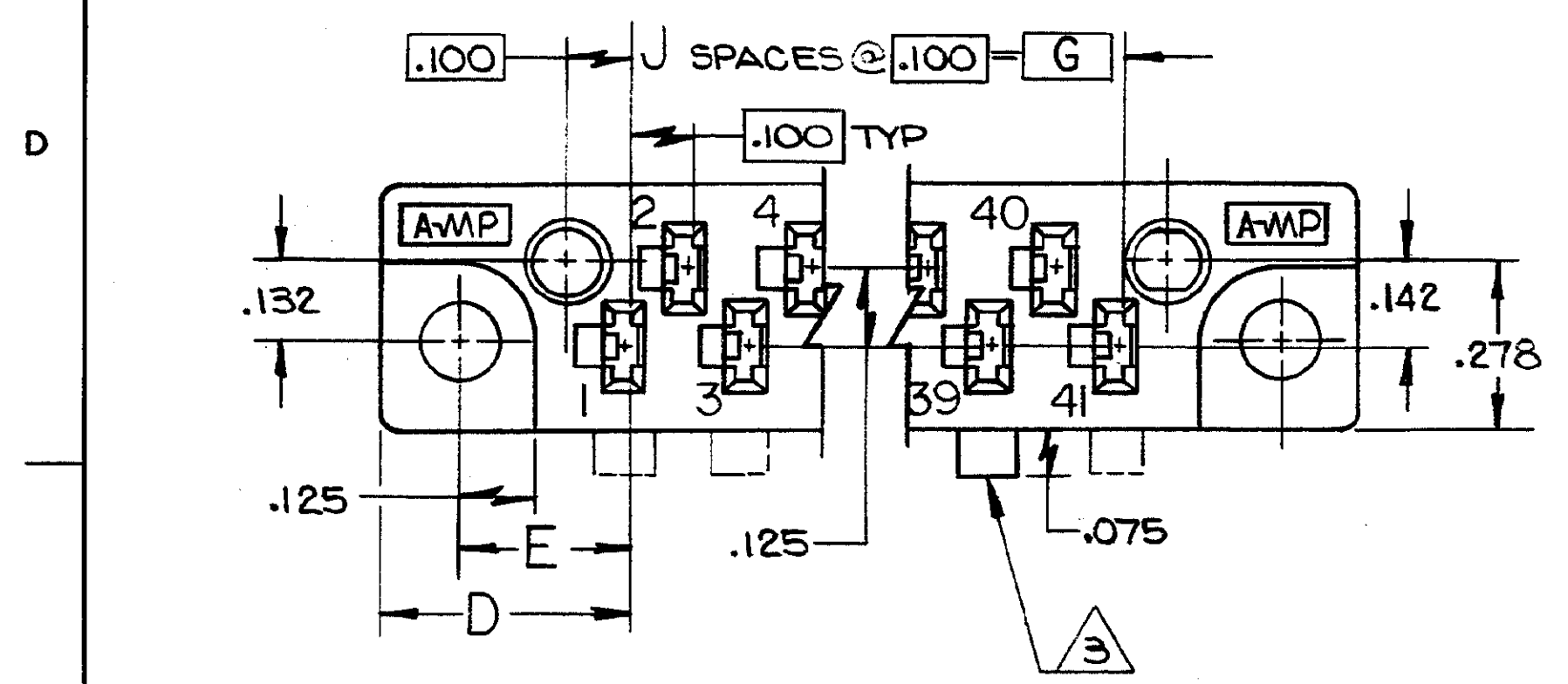

UNLESS OTHERWISE SPECIFIED DIMENSIONS ARE IN INCHES. TOLERANCES ON: DECIMALS $\pm .015$ ANGLES ± 10		CONTRACT NO 5-3-79	PART NO	
MATERIAL GLASS-FILLED POLYESTER COLOR: GREEN	DR IRSHAFFLER	CHK E. Parsons	AMP INCORPORATED Harrisburg, Pa.	
FINISH	APPD E. Parsons	APPD E. Parsons	NAME AMP BLADE RECEPTACLE HOUSING, .100 CENTERS	
	APPD R. Shawman	DSGN APPD	SIZE C	CODE IDENT NO 00779
	OTHER APPD		DRAWING NO 531590	SHEET 1 OF 2
			SCALE 4-1	

AMP 1471-6 REV 12-78

CUSTOMER DRAWING

531590

DRAWING MADE IN THIRD ANGLE PROJECTION

3

2

1

LOC DF HO

© COPYRIGHT 1979 BY AMP INCORPORATED, HARRISBURG, PA. ALL INTERNATIONAL RIGHTS RESERVED. AMP INCORPORATED PRODUCTS COVERED BY U. S. AND FOREIGN PATENTS AND/OR PATENTS PENDING.

REVISIONS					
P	F	ZONE	LTR	DESCRIPTION	DATE APPROVED
02	✓		02		
✓	✓	P		OBS 7, 8, 9, 10, 11, 12 ECADDF 0944	21 11.80 JW

- ① 'AMP', PART NO. & DATE CODE INK STAMPED WHITE THIS AREA.
- ② .0G2 (REF) NUMERALS MOLDED ON BOTH FACES OF HOUSING.
- ③ POLARIZING LUGS TO BE LOCATED AS SHOWN ON ALL ODD NUMBERED POSITIONS PER CHART BELOW.
- ④ OBS PART NO.

ALL ODD NO'S.	46	5.130	4.600	5.143	.399	.525	4.764	5.363	5.623	47	▲	1-531590-2
	40	4.297	4.000	4.310	.283	.408	4.164	4.530	4.790	41	▲	-1
	34	3.697	3.400	3.710			3.564	3.930	4.190	35	▲	-0
	28	3.097	2.800	3.110			2.964	3.330	3.590	29	▲	-9
	22	2.497	2.200	2.510			2.364	2.730	2.990	23	▲	-8
ALL ODD NO'S.	16	1.897	1.600	1.910	.283	.408	1.764	2.130	2.390	17	▲	-7
NONE	46	5.130	4.600	5.143	.399	.525	4.764	5.363	5.623	47		-6
	40	4.297	4.000	4.310	.283	.408	4.164	4.530	4.790	41		-5
	34	3.697	3.400	3.710			3.564	3.930	4.190	35		-4
	28	3.097	2.800	3.110			2.964	3.330	3.590	29		-3
	22	2.497	2.200	2.510			2.364	2.730	2.990	23		-2
NONE	16	1.897	1.600	1.910	.283	.408	1.764	2.130	2.390	17		531590-1
POLARIZING LUG LOCATION	J	H	G	F	E	D	C	B	A	NO OF POSITIONS		PART NO

UNLESS OTHERWISE SPECIFIED DIMENSIONS ARE IN INCHES.
TOLERANCES ON:
DECIMALS ±.015
ANGLES ± 1°

CONTRACT NO
DR IRSHAFFLER 5-3-79

CHK E. Parsons 5-14-79

APPD E. Parsons 5-14-79

APPD R. Shawman 5-15-79

DSGN APPD

OTHER APPD

AMP AMP INCORPORATED
Harrisburg, Pa.

NAME
AMP BLADE RECEPTACLE HOUSING
.100 CENTERS

SIZE CODE IDENT NO DRAWING NO
C 00779 531590

SCALE SHEET 2 OF 2

531590