



MODEL: GT-1405A
PRODUCT: Electro Magnetic Buzzer
EDITION: A/2016

THIS SPECIFICATION APPLIES TO THE MAGNETIC BUZZER

SPECIFICATION

Test condition: TEMP=+25±2 °C Related humidity=65±5% Air pressure:860-1060mbar

item	unit	specification	condition
rated voltage	Vo-p	3.0	
operating volt	Vo-p	2.0~4.0	
mean current	mA	35 Max	At rated voltage, 2000Hz square wave 1/2 duty
coil resistance	Ω	40±5	
sound output	dBA	85	At 10 cm(A-weight free air), at rated voltage 2000Hz, square wave, 1/2duty
rated frequency	Hz	2000	
operating temp	°C	-30 ~ +70	
storage temp	°C	-40 ~ +80	
dimension	mm	φ14.0×H5.0	See attached drawing
weight	gram	2.0	
material		PPO(Black)	
terminal		Pin type (Plating Au)	See attached drawing
environmental protection regulation		RoHS	

ENVIRONMENT TEST

item	test condition	evaluation standard
high temp. test	After being placed in a chamber at +70°C for 96 hours	After the test the part will meet specifications without any degradation in appearance and performance except SPL. after 4 hours at +25°C. The SPL will be in ±10dBA compared with initial one.
low temp. test	After being placed in a chamber at -30°C for 96 hours.	
thermal shock	The part will be subjected to 10 cycles. One cycle shall consist of:	

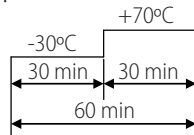

temp./humidity cycle	The part will be subjected to 10 cycles. One cycle shall be 24 hours and consist of:
----------------------	---

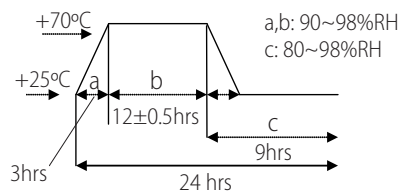



MODEL: GT-1405A
PRODUCT: Electro Magnetic Buzzer
EDITION: A/2016

RELIABILITY TEST

item	test conditions	evaluation standard
operating life test	ORDINARY TEMPERATURE The part will be subjected to 1000 hours of continuous operation at room temperature (+25±10°C)	After the test the part will meet specifications without any degradation in appearance and performance except SPL. after 4 hours at +25°C. The SPL would be in ±10dBA compared with initial one.
	HIGH TEMPERATURE The part will be subjected to 500 hours of continuous operation at +60°C with 3.0V , 2000Hz applied.	
	LOW TEMPERATURE The part will be subjected to 500 hours of continuous operation at -20°C with 3.0V, 2000Hz applied.	

TEST CONDITION

Standard Test Condition : a)Temperature: +5~+35°C b)Humidity:45~85% c)Pressure: 860~1060mbar

MECHANICAL CHARACTERISTICS

item	test condition	evaluation standard
solderability	Lead terminal are immersed in rosin for 5seconds and then immersed in solder bath of +230±5°C for 3±0.5 second	90% min.lead terminals will be wet with solder No interference in operation
soldering heat resistance	Lead terminal are immersed in soldering bath of +230±5°C for 3±0.5 second.	
terminal mechanical strength	Apply the terminal with 1 KG of tension for 1 minute	No damage and cutting off
vibration	The part will be subjected to a vibration cycle of 10Hz to 55Hz to 10Hz in a period of 1 minute. Total peak amplitude will be 1.52mm(9.3G). The vibration test will consist of 2 hours per axis in each three axes (X,Y,Z). Total 6 hours.	After the test the part will meet specifications without any damage in appearance and performance except SPL. SPL would be in ±10dBA compared with initial one.
drop test	The part only will be dropped from a height of 75cm onto a 40mm thick wooden board 3 times in 3 axes(X,Y,Z). Total of 9 times.	

DIMENSION

UNITS = MM

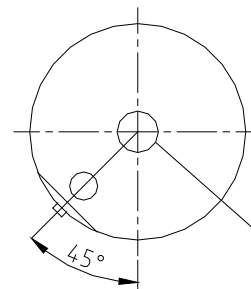
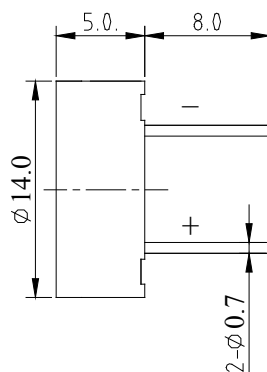
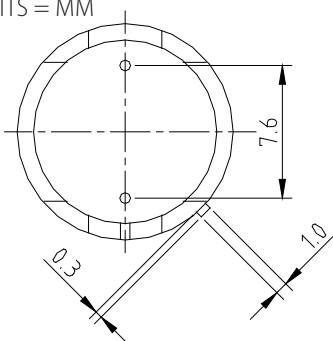

Sound Emission Hole
 φ2.6

Tolerance:±0.5 Unit:mm



MODEL: GT-1405A
PRODUCT: Electro Magnetic Buzzer
EDITION: A/2016

Soberton Inc.

MEASUREMENT TEST CIRCUIT

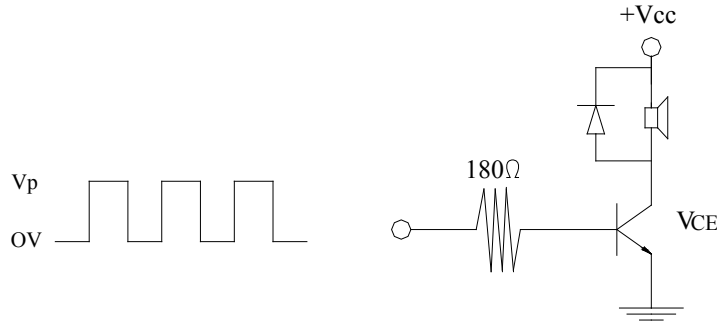

INSPECTION FIXTURE

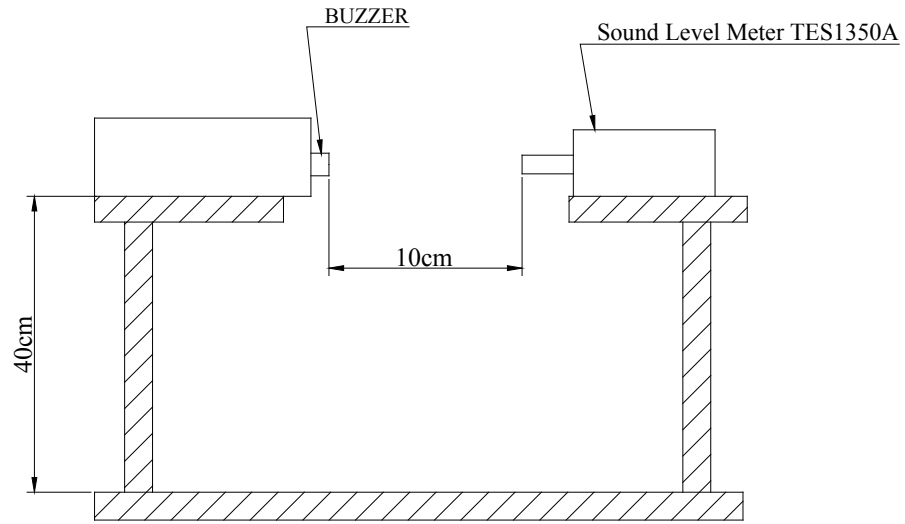

PACKING

